

# Knitting Chair



Lounge Chair

Furniture—Product Sheet  
[menu.as](http://menu.as)

by Ib Kofod-Larsen



# Knitting Chair



Designed by Ib Kofod-Larsen in 1951 and re-launched by MENU in 2018, the Knitting Chair is now reimagined in new upholstery fabrics, bringing with it the opportunity to customise the classic design to suit modern sensibilities. The first classic furniture design produced by MENU, the chair's characteristic cutaway elbows and curved, conical back offer optimal sitting comfort. Handmade in Sweden by skilled craftspeople, the Knitting Chair's distinctive triangular silhouette, cutaway sides and low pitch bring personality to any room.

Defined by an exposed, triangular construction, a gently curved seat and back ideally pitched for relaxation, and distinctive cut-outs for resting the elbows when reading, Ib Kofod-Larsen's Knitting Chair is a masterful example of proportion and unexpected, sculptural form. Beautiful from every angle, the lounge chair is easy to fit into any room layout. Despite the chair's enveloping comfort, it has a relatively small footprint, making it a match for both compact and more spacious interiors. Since its re-launch by MENU in 2018, bringing the sophisticated, inventive design to a new generation of design connoisseurs, its enveloping comfort has been synonymous with inventive design. Now updated with a range of new upholstery fabrics, the lounge chair enters a new chapter in its history with all the hallmarks of great craftsmanship.

## About the Designer

Danish-born architect and furniture designer Ib Kofod-Larsen (1921–2003) earned his architecture degree from the Royal Danish Academy in Copenhagen, opening his own studio in Copenhagen in 1948. A prominent figure in Danish Modernism alongside such masters as Kaare Klint, Hans J. Wegner, Børge Mogensen, Finn Juhl and Nanna Ditzel, Kofod-Larsen viewed Scandinavian design not as a regional phenomenon but as part of international modernism. He enjoyed great success internationally, becoming the best-selling Danish architect in the US in the 50s, working with furniture manufacturers in Germany, Sweden, Japan, the US and the UK, and exhibiting

## Product Type

Lounge Chair

## Environment

Indoor

## Dimensions (cm / in)

H: 90,6 cm / 35,7"

W: 71,3 cm / 28,1"

D: 66,9 cm / 26,3"

SH: 30 cm / 11,8"

## Colours

Shell: According to Upholstery

Base: Natural Oak or Dark Stained Oak

# Knitting Chair

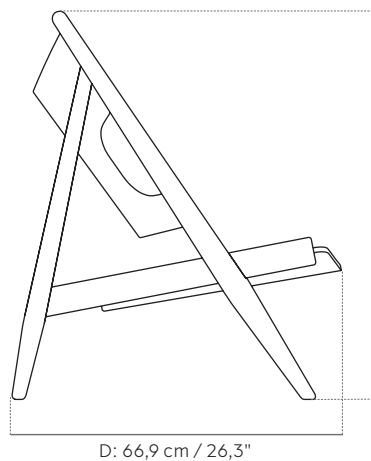

H: 90,6 cm / 35,7"

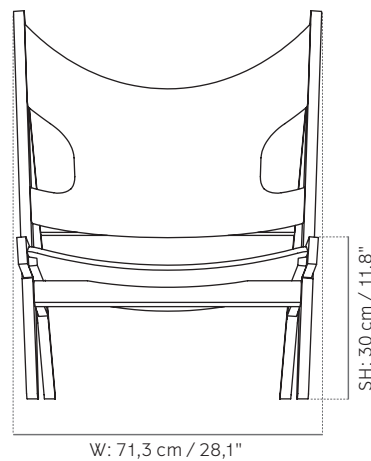

SH: 30 cm / 11,8"

## Production Process

The solid oak frame is CNC milled and treated with a Wax-Oiled finish. Seat and backrest are made from form-pressed plywood and upholstered. All assembly is made by hand.

## Materials

Wax-Oiled Solid Oak, Plywood.  
Upholstered with Textile or Leather

## Colour RAL Code

According to Upholstery

## Weight item (kg)

11 kg

## Test

N/A

## Certifications

N/A

## Packaging Type

Brown Box

## Packaging Measurement (H \* D \* W)

95 cm \* 80 cm \* 75 cm

## Care Instructions

Seat, Back: Should be cleaned according to the recommendations of the textile / leather supplier.

Frame: Use a soft dry cloth to clean. Do not use any cleaners with chemicals or harsh abrasives. Avoid using water.

# Knitting Chair



Colline 118 / Dark Stained Oak  
9680079



Dakar 0250 / Natural Oak  
9681979